



- Established* 1952 - Hanwha Group, 1969 - Hanwha L&C Corp.
- Global Headquarters* Hanwha L&C Corporation
Hanwha Bldg,
1 Changgyo-dong, Chung-gu
Seoul, Korea 100-797
- North American Office* Hanwha L&C | Surfaces
2839 Paces Ferry Rd.
Suite 200
Atlanta, GA 30339
- Distribution Centers* We have an extensive network of distributors across North America.
To locate a distributor in your area, visit our website: hanwhasurfaces.com.
- Product Overview* Hanex Solid Surfaces is an ideal material for residential and commercial applications. The beauty, aesthetics, and design flexibilities along with hygienic features are only some of the advantages. Hanex Solid Surfaces products are non-porous and NSF-51 certified for food preparation areas. The design flexibility and usability of Hanex Solid Surfaces makes it truly “solid” in surfacing materials.
- Product Information* Toll Free 888.426.9421
Direct 770.431.6110
Website hanwhasurfaces.com



Hanwha Surfaces is a division of Hanwha L&C, the USA subsidiary of Hanwha, a global conglomerate based in Korea. The company has more than 33 overseas and domestic companies with an annual sales revenue of more than \$40 billion. Among the vast variety of businesses, Hanwha Surfaces specializes in a comprehensive array of surfacing solutions including HanStone[®] Quartz and Hanex Solid Surfaces.

History:

Hanwha was founded in 1952 under the name Korea Explosives Corporation and successfully developed its own industrial explosives production. Localization of the explosives accelerated the reconstruction of the Korean economy after the Korean War. In 1993, Korea Explosives Corporation changed the name to Hanwha Corporation and diversified the business area into construction, trades, machinery, and pharmaceuticals in order to be a world business leader. The firm now deals in a diverse range of industries including chemicals, plastics, machinery, telecommunications, biotechnology, finance and building materials.

Hanex Solid Surfaces

Hanex Solid Surfaces is an ideal material for residential and commercial applications because of its beauty, durability, aesthetics, design flexibility, and color choices. Hanex Solid Surfaces products are non-porous material and NSF 51 Certified for food preparation areas. They can be used in many applications where sanitation is of utmost importance, such as kitchen countertops, hospitals, playrooms, schools and many more. Hanex Solid Surfaces can be fabricated and installed in almost any application with invisible seams.

Every Hanex Solid Surface is covered by the best Limited Warranty in the industry. We are backed by a nationwide network of industry experts, authorized repair agents and customer care associates to service your countertop.

Features and Benefits

- Stain resistance
- Mildew resistance
- Bacteria resistance
- Class-A fire rating
- Non-porous
- Hygienic
- Repairable
- Custom design
- Thermoformable
- Custom edges details
- Industry's best warranty
- Design flexibility
- Inconspicuous seams
- Durable
- Renewable

Hanex | Collections and Colors

The Classics:

This collection brings you endless design possibilities with a wide variety of color combinations, textures and hues - inspired by the wonder of nature.

Solo: Array of solid colors to address clean, traditional designs

Duo: Arrangement of small particulate colors to provide soft, natural designs

Trio: Arrangement of large particulate colors to provide natural stone appearance

Palazzo: Arrangement of unique designs and color representing innovation and advancement of technology

Constellation: A uniquely modern pattern with a subtle metallic shimmer

Brionne:

Crisp, clean and pure describes the essence of Brionne. This unique collection features a soft, luminous sheen, and a rich array of patterns and colors. No matter what combination of shapes and hues you choose, the result is sure to be visually pleasing.

Bellissimo:

Inspired by patterns and colors found in nature, the Bellissimo collection creates a luxurious, sophisticated design appeal - all while being distinctively green.

Applications

Hanex Solid Surfaces is an ideal hygienic material for kitchens and baths due to its resistance to heat, moisture, pollutants, bacteria, and other harmful agents. With a wide selection of colors and design applications, Hanex Solid Surfaces can transform any space into a beautiful environment. The unlimited design flexibility of Hanex Solid Surfaces makes it a perfect material for commercial applications. Many commercial builders are using solid surfaces in hospitals, restaurants, hotels, schools, banks, and other areas because of all the advantages a solid surface has to offer.



1. *What is Hanex Solid Surfaces?*

Hanex Solid Surfaces is an ideal material for residential and commercial application because of its beauty, durability, aesthetics, design flexibility, color choices, and more. Hanex Solid Surfaces are non-porous material and NSF 51 Certified for food preparation areas. They can be applied in many applications where sanitation is of utmost importance, such as kitchen countertops, hospitals, playrooms, schools and much more.

2. *What is Hanex Solid Surfaces made of?*

Hanex Solid Surfaces is a composition of Methyl Methacrylate (MMA) and Poly Methyl Methacrylate (PMMA) resin filled with Alumina Trihydrate (ATH) and other specialized formula to give them the timeless beauty and quality. We are one of a few to have successfully developed the DBCU (Double Belt Casting Unit) process that produces superior products.

3. *Can I receive some Hanex Solid Surfaces samples?*

Hanex Solid Surfaces samples are provided to help designers, architects, and customers make the right selection from the vast array of colors and designs. Please visit our website (hanwhasurfaces.com) or contact our office to order samples.

4. *Is Hanex Solid Surfaces repairable?*

Unlike other surfacing materials, Hanex Solid Surfaces can be repaired to its original condition. Hanex Solid Surfaces is non-porous and solid throughout the entire material. These features make Hanex Solid Surfaces virtually maintenance free and completely repairable. Please visit our Care & Maintenance section for more details.

5. *How do I clean and take care of my Hanex Solid Surfaces countertop?*

Unlike other surfacing materials, Hanex Solid Surfaces is non-porous and solid through the entire material. These features make Hanex Solid Surfaces virtually maintenance free and repairable. To ensure long-lasting beauty, follow the guidelines to prevent damages and care for your investment. Please visit our Care & Maintenance section for more details.

6. *What is NSF 51?*

According to NSF's website, independent testing programs require companies to comply with the strict standards imposed by NSF and its product certification programs. From extensive product testing, material analyses to unannounced plant inspections, NSF is the only third-party testing organization to undertake such a complete evaluation. NSF must inspect every aspect of product's development before it can be certified. NSF 51 is a certification program which specifically concentrates on food preparation areas. NSF imposes the strictest standards to ensure consumer health and safety. We are proud to state that Hanex Solid Surfaces has been tested by NSF, certified, and is currently listed as NSF 51 Certified.

7. *Are there different finishes in Hanex Solid Surfaces?*

Hanex Solid Surfaces can be finished to have matte, semi-gloss and high-gloss finish. Remember, some colors may require more maintenance with a different finish.

8. *I am still confused about heat-resistance properties of Hanex Solid Surfaces.*

The innate feature of Hanex Solid Surfaces gives it excellent heat resistant property compared to other surfacing materials in the market. However, to prevent any damages from heat, never place hot items directly on Hanex Solid Surfaces. Placing hot pans or heat-generating appliances directly on Hanex Solid Surfaces may cause damages to the countertop. Avoid direct and indirect heat with temperatures over 80° C (170° F). In most cases the damages can be repaired, however to protect the Hanex Solid Surfaces countertop, recommend your customer always use trivets when placing hot items or heat-generating appliances.

9. *What are the advantages of Hanex Solid Surfaces over granite countertops?*

With the beauty of granite, there are many limitations. If granite is not properly sealed regularly it can easily be stained, harbor bacteria, molds, viruses, and other germs that can be hazardous to your health. Depending on the size of the countertop, granite countertops will have visible seams and other imperfections that may cause problems. There are many other benefits of Hanex Solid Surfaces over granite, most importantly, Hanex Solid Surfaces is fully repairable and renewable. Unlike granite, Hanex Solid Surfaces comes with a Commercial 10-Year Limited Warranty or Residential Lifetime Limited Warranty.

10. What are the advantages of Hanex Solid Surfaces over laminate countertops?

Laminates over time will separate due to moisture. Hanex Solid Surfaces is non-porous, solid, and homogenous. The water absorption ratio is among the lowest in the industry. Even after years of daily use, Hanex Solid Surfaces will not soak up moisture. There are many other benefits of Hanex Solid Surfaces over laminates, however. Most importantly, Hanex Solid Surfaces is fully repairable and renewable. Additionally, unlike laminates, Hanex Solid Surfaces comes with a Commercial 10-Year Limited Warranty or a Residential Lifetime Limited Warranty.

11. What are the advantages of Hanex Solid Surfaces over tile countertops?

Hanex Solid Surfaces can be fabricated and installed in almost any application with invisible seams, making Hanex Solid Surfaces truly solid in surfacing materials. Unlike tiles, you don't have to clean or disinfect, and it doesn't harbor bacteria, viruses or germs. There are many other benefits of Hanex Solid Surfaces over tiles, most importantly, Hanex Solid Surfaces are fully repairable and renewable.

12. What are the advantages of Hanex Solid Surfaces over the other countertops materials like wood, concrete, stainless steel...?

Hanex Solid Surfaces is an ideal hygienic material for kitchens and baths due to its resistance to heat, moisture, pollutants, bacteria, and other harmful agents. With a wide selection of colors and design applications, Hanex Solid Surfaces can transform any space into a beautiful environment. The unlimited design flexibility of Hanex Solid Surfaces makes it a perfect material to use in commercial applications. Many commercial builders are using solid surfaces in hospitals, restaurants, hotels, schools, banks and other areas because of all the advantages solid surface has to offer.

13. What does the warranty cover?

Hanex Solid Surfaces comes with a Commercial 10-Year Limited Warranty or a Residential Lifetime Limited Warranty, the best in the industry. Due to its inherent properties and its DBCU manufacturing process, Hanex Solid Surfaces name is recognized in the industry for quality.



Product Information

1. Product Name: Hanex® Solid Surfaces

2. Product Description: Solid Surface sheets in 30" x 144" x ½"

3. Product Composition:

Hanex Solid Surfaces are made with a composition of Methyl Methacrylate (MMA) and Poly Methyl Methacrylate (PMMA) resin filled with Alumina Trihydrate (ATH) and other specialized formats to give them timeless beauty and quality. Hanex Solid Surfaces sheets are made using state of the art DBCU (Double Belt Casting Unit) process to produce superior products.

4. Product Characteristics:

- Thermal Stability

The resistance without change in color and shape when heat is applied to the material from an outside source, including direct and/or indirect heat source. Hanex Solid Surfaces has been tested and passed the following tests:

- Heat resistance
- Hot water resistance
- Weatherability
- UV stability
- Flame resistance

- Chemical Resistance

The resistance to certain acid, alkali and organic solvent without change in color and composition. Hanex Solid Surfaces has been tested under the strictest guidelines.

- Maintenance/Repairability

Unlike other surfacing materials which are produced by laminating or coating, Hanex Solid Surfaces is non-porous and solid through the entire material. These features make Hanex Solid Surfaces virtually maintenance free and fully repairable.



5. Applications:

- Residential
 - Countertops
 - Wall coverings
 - Vanities
 - Aprons
 - Window sills
 - Thresholds
 - Shelves
 - Fireplaces
 - Bar tops
 - Shower and bath surrounds

- Commercial
 - Table tops
 - Countertops
 - Signs
 - Reception areas
 - Transactions counters
 - Name plates
 - Wall coverings
 - Bar tops
 - Window sills
 - Thresholds
 - Furniture
 - Partitions
 - Vanities
 - Shelves and store fixtures
 - Food service areas



6. Certifications

- NSF 51 (National Sanitation Foundation) for Food Preparation and Handling Area
- ISO 9001 (Quality Management System)
- ISO 14001 (Environment Management System)
- UL (Universal Laboratory)

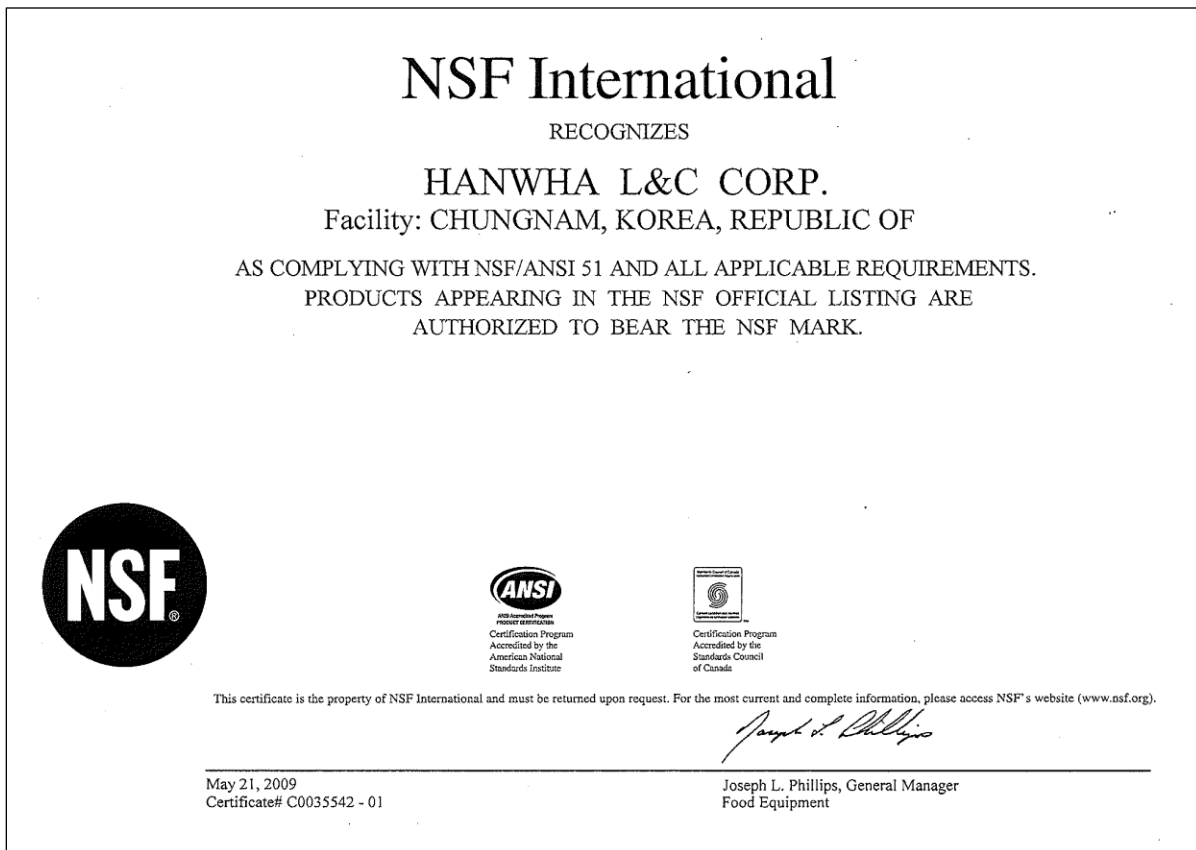

National Sanitation Foundation (NSF 51 for Food Zone)



Certifications Continued...

CERTIFICATE

QUALITY MANAGEMENT SYSTEM



Korean Foundation for Quality

..... 2000.00 - 2010.1/1, 20
 a. 200t. 01. 2t
 .. 1Q95. 07. 30
 C..... AC00100

HANWHA L&C CO., LTD
HEAD OFFICE AND BUKANG PLANT

- HEAD OFFICE : 1, Janogryoc ong, Bukang, KotN
- FIRST PLANT : 801, Bugangri, Bukang, KotN
- SECOND PLANT : 22V, Goll-buk-do, rea

Korean Foundation for Quality certifies that The Quality Management System of the above organization has been audited and has complied with the requirements of the following standard



Standards

KS Q ISO 9001:2009 ■ ISO 9001:2008

Scope of certification

- FIRST PLANT DESIGN, DEVELOPMENT, PRODUCTION AND SALES OF FLOORING, WINDOW-PANEL, WINDOW SETS, DOOR SETS, SMC(SHEET MOLDING COMPOUND), PVC-RIGID FLOOR, PVC TILE AND CARPET TILE
- SECOND PLANT DESIGN, DEVELOPMENT, PRODUCTION AND SALES OF GMT(GLASS FIBER WET REINFORCED THERMOPLASTIC), GMT MOLDING PRODUCTION, EXPANDED POLYPROPYLENE, SUMPER CORE, ARTIFICIAL ACRYLIC MARBLE, FLEXIBLE COPPER CLAD WALLPAPER, COVERLAY, ENGINEERED STONE

IQNet

Printed by KfQ

Quality Management System (ISO9001)



Certifications Continued...



THE INTERNATIONAL CERTIFICATION NETWORK

CERTIFICATE

IONet and
KFO
hereby certify that the organization

HANWHA L&C BUKANG PLANT

- FIRST PLANT : 801, Bugang-ri, Suyong-myeon, Cheongwon-gm, ChwlgheonQbl.lkoOo, Korea
- SECOND PLANT : 229, Gewnflo.ri, Buyong-myeon-Cheoogwon.gun. Chunoet.eongbuk-do.-Korea

for the following activities

- FIRST PLANT : PRODUCTION OF FLOORING, WINDOW-PROFILE, WINDOW SETS, DOOR SETS, SMC(SHEET MOULDING COMPOUND), PVC-FLOORING FILM, PVC WALL COVERING CARPET
- SECOND PLANT : PRODUCTION OF GMT(GLASS FIBER MAT REINFORCED THERMOPLASTIC) GMT MOLDING PRODUCTION, EPP(EXPANDED POLYPROPYLENE), RUBBER CORE, ARTIFICIAL ACRYLIC MARBLE, FLEXIBLE COPPER CLADDING MATERIAL, COVERLAY AND KANSTONE(ENGINE ROOM STONE)

has implemented and maintains an **Environmental Management System** which fulfills the requirements of the following standard

ISO 14001:2004

Issued on : 2007 10 26
Validity date : 2010 07 23

Registration Number: KR - 02779





Riethof
Prüfungsinstitut



Jae Ryong Kim
President & CEO of KFQ



IONet Partners:

AENOR Spain AFAQ AFNOR France AIB-Vincotte International Belgium ANCE Mexico APCRR Portugal CISO Italy CQC China CQM China CQS Czech Republic Cro Cert Croatia DQS Germany DS Denmark ELIT Greece FCAV Brazil FONDONORMA Venezuela HQAA Hong Kong China ICONTEC Colombia IMC Mexico Inspector Certification Finland IRAM Argentina JQA Japan KFQ Korea MSZT Hungary Nemko AS Norway NSAI Ireland PCBC Poland QMI Canada Quality Austria Austria RR Russia SAI Global Australia SII Israel SIQ Slovenia SIBIM QAS International Malaysia SQS Switzerland SRAC Romania TEST St Petersburg Russia YUQS Serbia

IONet is represented in the USA by: AFAQ AFNOR, AIB-Vincotte International, CISO, DQS, NSAI Inc., QMI and SAI Global

* The list of IONet partners is valid at the time of issue of this certificate. Updated information is available under www.ionet-certification.com

Quality Management System (ISO14001)



Certifications Continued...



THE INTERNATIONAL CERTIFICATION NETWORK

CERTIFICATE

IQNetland
KFQ

hereby certify that the following organization

HANWHA L&C CO., LTD

HEAD OFFICE AND BUKANG PLANT

• HEAD OFFICE : 1, Janggyo-dong, Jung-gu, Seoul Korea
 • FIRST PLANT : 801, Bugang-d. Bityoog-myeon, Cheongwon-gun, Choongcheongbuk-do, Korea
 • SECOND PLANT : 229, Geumhr-Hi, Buyong-myeon, Cheongwoo-gun, Chungcheongbuk-do, Korea

for the following activities

• DESIGN, DEVELOPMENT, PRODUCTION AND SALES OF FLOORING, WINDOW WALL, WINDOW SETS, DOOR SETS, SHEET JOINING COMPOUND, PVC-RIGID FILU, PVC TILE AND CARPET TILE
 • SECOND PLANT : DESIGN, DEVELOPMENT, PRODUCTION AND SALES OF GMT (FIBER MAT REINFORCED THERMOPLASTIC), GMT (EXPANDED POLYPROPYLENE), BUMPER CORE, ARTIFICIAL MARBLE, FLOORING COPPER COATED LAMINATE, COVEBASE AND GRANITE (ENGINEERED STONE)

has implemented and maintain a

Quality Management System

which fulfills the requirements of the following standard

ISO 9001:2008

Issued on : 2009. 09. 28
 Validity date : 2010. 07. 29

Registration Number: KR - 00100



(2,.)

Retre Hosmer
President of IQNet

&ti

Jue Ri (Jung Kim)
CEO of IQNet

IQNet is a registered trademark of IQNet. All rights reserved. IQNet is not responsible for the content of this certificate. The certificate is valid only for the activities mentioned above. The certificate is issued on the condition that the organization has implemented and maintained a Quality Management System conforming to the requirements of the ISO 9001:2008 standard. The certificate is issued for a period of 2 years. The certificate is subject to annual surveillance audits. The certificate is issued for a period of 2 years. The certificate is subject to annual surveillance audits. The certificate is issued for a period of 2 years. The certificate is subject to annual surveillance audits.

Quality Management System (ISO9001)



Certifications Continued...



Hanex
Hanwha L&C USA LLC

This product has been certified according to the GREENGUARD Indoor Air Quality (IAQ) Certification Program for Low Emitting Products

Reference Standard: GGPS.001 GREENGUARD IAQ Standard for Building Materials, Finishes, and Furnishings

Product Type: Furniture Components/Materials, Seating, and Free Standing Furniture and Furnishing Units

Certificate of Compliance

Certification Details:

Certificate No: S10Sm9004811-2

Status: Certified

Period: 10/2007 - 10/2010

Restrictions: NONE

Criteria	Allowable Limits
TVOC ¹	< 0.25 mg/m ³
Formaldehyde	< 0.025 ppm
Total Aldehydes ²	< 0.05 ppm
Individual VOCs ³	< 0.1 TLV
4-phenylcyclohexene	< 0.0033 mg/m ³

Listing of measured carcinogens and reproductive toxins as identified by California Proposition 65, the U.S. National Toxicology Program (NTP), and the International Agency on Research on Cancer (IARC) must be provided.

Any pollutant regulated as a primary or secondary outdoor air pollutant must meet a concentration that will not generate an air concentration greater than that promulgated by the National Ambient Air Quality Standard (U.S. EPA, code of Federal Regulations, Title 40, Part 50).

See referenced standard for a complete technical explanation.

¹Defined to be the total response of measured VOCs falling within the C₆-C₁₆ range, with responses calibrated to a toluene surrogate.

²Defined to be the total response of a target list of aldehydes (2-butenal; acetaldehyde; benzaldehyde; 2, 5-dimethylbenzaldehyde, 2-methylbenzaldehyde; 3-and/or 4-methylbenzaldehyde; butanal; 3-methylbutanal; formaldehyde; hexanal; pentanal; propanal), with each individually calibrated to a compound specific standard.

³Any pollutant not listed must produce an air concentration level no greater than 1/10 the Threshold Limit Value (TLV) industrial work place standard (Reference: American Conference of Government Industrial Hygienists, 6500 Glenway, Building D-7, Cincinnati, Ohio 45211-4438).

GREENGUARD Certification affirms that products meet the criteria of the referenced standard and the requirements of the specific certification program. Certification testing is conducted according to a consistent, defined protocol. The testing does not evaluate emissions under usage conditions other than those defined in the protocol and does not address potential environmental impact other than chemical and particle emissions.

The GREENGUARD Environmental Institute (GEI) is an industry independent, third-party certification organization that qualifies products for low chemical emissions. GREENGUARD Certification programs use defined product standards, test methodologies, product sample collection and handling procedures, program application processes and on-going verification procedures. GREENGUARD standards, methods, and procedures are available at www.GREENGUARD.org.

© 2010 GREENGUARD Environmental Institute
GGPC.001D



Certifications Continued...



Hanex
Hanwha L&C USA LLC

This product has been certified according to the GREENGUARD Children & Schools Certification Program for Low Emitting Products

Reference Standard: GGPS.002 GREENGUARD Children & Schoolssm Standard

Product Type: All Products

Certificate of Compliance

Certification Details:

Certificate No: S10Sm9004811-2

Status: Certified

Period: 10/2007 - 10/2010

Restrictions: NONE

Criteria	Allowable Limits
Individual VOCs ¹	< 1/100 TLV and < ½ CA chronic REL
Formaldehyde	< 0.0135 ppm /13.5 ppb
TVOC ²	< 0.22 mg/m ³
Total Aldehydes ³	< 0.043 ppm /43 ppb
Total Phthalates ⁴	< 0.01 mg/m ³
Total Particles ⁵	< 0.02 mg/m ³

See referenced standard for a complete technical explanation.
Complies with California Department of Health Services' "Standard Practice for the Testing of Volatile Organic Emissions from Various Sources Using Small-Scale Environmental Chambers" (CA section 01350)

¹Any VOC not listed must produce an air concentration level no greater than 1/100 the Threshold Limit Value (TLV) industrial work place criterion (Reference: American Conference of Government Industrial Hygienists, 6500 Glenway, Building D-7, Cincinnati, Ohio 45211-4438) and no greater than 1/2 the CA Chronic Reference Exposure Level (CREL) http://www.oehha.ca.gov/air/chronic_rels/AllChrels.html - (CRELs) Adopted by the State of California Office of Environmental Health Hazard Assessment (OEHHA), December 2008).

²Defined to be the total response of measured VOCs falling within the C₆-C₁₆ range, with responses calibrated to a toluene surrogate.

³Defined to be the total response of a target list of aldehydes (2-butenal; acetaldehyde; benzaldehyde; 2, 5-dimethylbenzaldehyde, 2-methylbenzaldehyde; 3-and/or 4-methylbenzaldehyde; butanal; 3-methylbutanal; formaldehyde; hexanal; pentanal; propanal), with each individually calibrated to a compound specific standard.

⁴Total phthalates include dibutyl (DBP), diethylhexyl (DEHD), diethyl (DEP), butylbenzyl (BBP), di-octyl (DOP), and dimethyl (DMP) phthalates.

⁵Particles are only applicable to fibrous, particle-releasing products with exposed surface area in air streams.

GREENGUARD Certification affirms that products meet the criteria of the referenced standard and the requirements of the specific certification program. Certification testing is conducted according to a consistent, defined protocol. The testing does not evaluate emissions under usage conditions other than those defined in the protocol and does not address potential environmental impact other than chemical and particle emissions.

The GREENGUARD Environmental Institute (GEI) is an industry independent, third-party certification organization that qualifies products for low chemical emissions. GREENGUARD Certification programs use defined product standards, test methodologies, product sample collection and handling procedures, program application processes and on-going verification procedures. GREENGUARD standards, methods, and procedures are available at www.GREENGUARD.org.

© 2010 GREENGUARD Environmental Institute
GGPC.002



Certifications Continued...



Brionne
Hanwha L&C USA LLC

This product has been certified according to the GREENGUARD Indoor Air Quality (IAQ) Certification Program for Low Emitting Products

Reference Standard: GGPS.001 GREENGUARD IAQ Standard for Building Materials, Finishes, and Furnishings

Product Type: Furniture Components/Materials, Seating, and Free Standing Furniture and Furnishing Units

Certificate of Compliance

Certification Details:

Certificate No: S10Sm9004811-1

Status: Certified

Period: 10/2007 - 10/2010

Restrictions: NONE

Criteria	Allowable Limits
TVOC ¹	< 0.25 mg/m ³
Formaldehyde	< 0.025 ppm
Total Aldehydes ²	< 0.05 ppm
Individual VOCs ³	< 0.1 TLV
4-phenylcyclohexene	< 0.0033 mg/m ³

Listing of measured carcinogens and reproductive toxins as identified by California Proposition 65, the U.S. National Toxicology Program (NTP), and the International Agency on Research on Cancer (IARC) must be provided.

Any pollutant regulated as a primary or secondary outdoor air pollutant must meet a concentration that will not generate an air concentration greater than that promulgated by the National Ambient Air Quality Standard (U.S. EPA, code of Federal Regulations, Title 40, Part 50).

See referenced standard for a complete technical explanation.

¹Defined to be the total response of measured VOCs falling within the C₆-C₁₆ range, with responses calibrated to a toluene surrogate.

²Defined to be the total response of a target list of aldehydes (2-butenal; acetaldehyde; benzaldehyde; 2, 5-dimethylbenzaldehyde, 2-methylbenzaldehyde; 3-and/or 4-methylbenzaldehyde; butanal; 3-methylbutanal; formaldehyde; hexanal; pentanal; propanal), with each individually calibrated to a compound specific standard.

³Any pollutant not listed must produce an air concentration level no greater than 1/10 the Threshold Limit Value (TLV) industrial work place standard (Reference: American Conference of Government Industrial Hygienists, 6500 Glenway, Building D-7, Cincinnati, Ohio 45211-4438).

GREENGUARD Certification affirms that products meet the criteria of the referenced standard and the requirements of the specific certification program. Certification testing is conducted according to a consistent, defined protocol. The testing does not evaluate emissions under usage conditions other than those defined in the protocol and does not address potential environmental impact other than chemical and particle emissions.

The GREENGUARD Environmental Institute (GEI) is an industry independent, third-party certification organization that qualifies products for low chemical emissions. GREENGUARD Certification programs use defined product standards, test methodologies, product sample collection and handling procedures, program application processes and on-going verification procedures. GREENGUARD standards, methods, and procedures are available at www.GREENGUARD.org.

© 2010 GREENGUARD Environmental Institute
GGPC.001D



Certifications Continued...



GREENGUARD®
Indoor Air Quality Certified

Certificate of Compliance

Brionne
Hanwha L&C USA LLC

This product has been certified according to the GREENGUARD Children & Schools Certification Program for Low Emitting Products

Reference Standard: GGPS.002 GREENGUARD Children & Schoolssm Standard

Product Type: All Products

Criteria	Allowable Limits
Individual VOCs ¹	< 1/100 TLV and < ½ CA chronic REL
Formaldehyde	< 0.0135 ppm /13.5 ppb
TVOC ²	< 0.22 mg/m ³
Total Aldehydes ³	< 0.043 ppm /43 ppb
Total Phthalates ⁴	< 0.01 mg/m ³
Total Particles ⁵	< 0.02 mg/m ³

See referenced standard for a complete technical explanation.
Complies with California Department of Health Services' "Standard Practice for the Testing of Volatile Organic Emissions from Various Sources Using Small-Scale Environmental Chambers" (CA section 01350)

¹Any VOC not listed must produce an air concentration level no greater than 1/100 the Threshold Limit Value (TLV) industrial work place criterion (Reference: American Conference of Government Industrial Hygienists, 6500 Glenway, Building D-7, Cincinnati, Ohio 45211-4438) and no greater than 1/2 the CA Chronic Reference Exposure Level (CREL) http://www.oehha.ca.gov/air/chronic_rels/AIChrels.html - (CRELs) Adopted by the State of California Office of Environmental Health Hazard Assessment (OEHHA), December 2008).

²Defined to be the total response of measured VOCs falling within the C₆-C₁₆ range, with responses calibrated to a toluene surrogate.

³Defined to be the total response of a target list of aldehydes (2-butenal; acetaldehyde; benzaldehyde; 2, 5-dimethylbenzaldehyde, 2-methylbenzaldehyde; 3-and/or 4-methylbenzaldehyde; butanal; 3-methylbutanal; formaldehyde; hexanal; pentanal; propanal), with each individually calibrated to a compound specific standard.

⁴Total phthalates include dibutyl (DBP), diethylhexyl (DEHD), diethyl (DEP), butylbenzyl (BBP), di-octyl (DOP), and dimethyl (DMP) phthalates.

⁵Particles are only applicable to fibrous, particle-releasing products with exposed surface area in air streams.

GREENGUARD Certification affirms that products meet the criteria of the referenced standard and the requirements of the specific certification program. Certification testing is conducted according to a consistent, defined protocol. The testing does not evaluate emissions under usage conditions other than those defined in the protocol and does not address potential environmental impact other than chemical and particle emissions.

The GREENGUARD Environmental Institute (GEI) is an industry independent, third-party certification organization that qualifies products for low chemical emissions. GREENGUARD Certification programs use defined product standards, test methodologies, product sample collection and handling procedures, program application processes and on-going verification procedures. GREENGUARD standards, methods, and procedures are available at www.GREENGUARD.org.

© 2010 GREENGUARD Environmental Institute GGPC.002



7. Dimensions (Hanex Solid Surfaces Sheets)

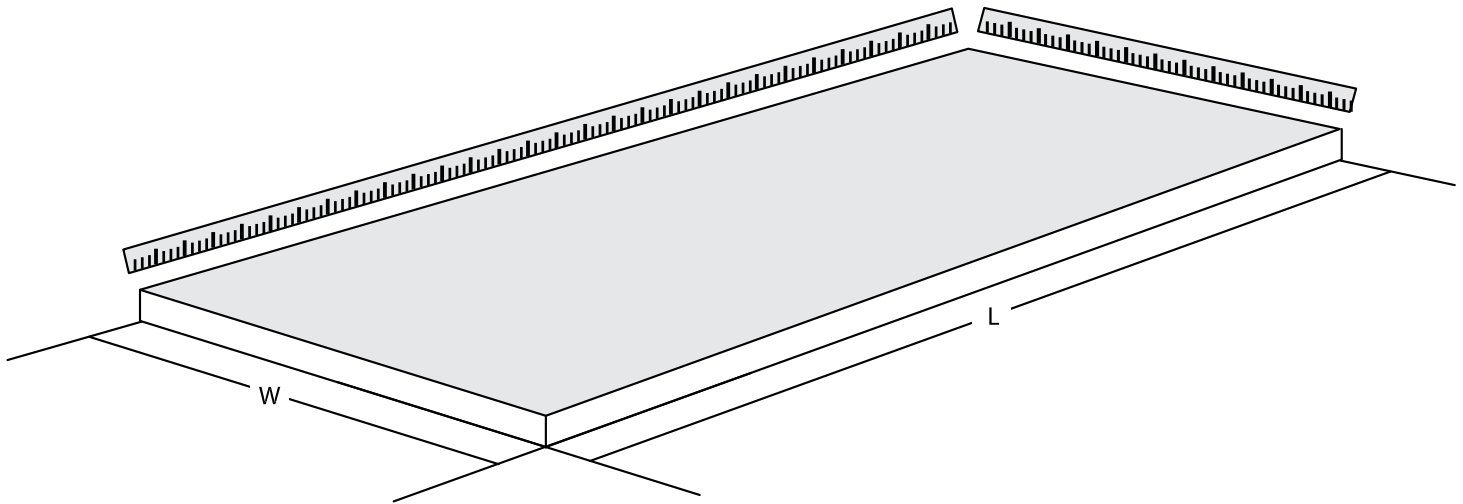

<i>Collection</i>	<i>Thickness inch (mm)</i>	<i>Width inch (mm)</i>	<i>Length inch (mm)</i>	<i>Weight lbs (kg)</i>
Classics (Solo)	¼" (6 mm)	30" (760 mm)	98" (2500 mm)	44.0 lbs (19.7 kg)
	½" (13 mm)		145" (3680 mm)	130.7 lbs (62.9kg)
Classics (Duo)	¼" (6 mm)	30" (760 mm)	98" (2500 mm)	44.0 lbs (19.7 kg)
	½" (13 mm)		145" (3680 mm)	130.7 lbs (62.9kg)
Classics (Trio)	½" (13 mm)	30" (760 mm)	145" (3680 mm)	130.7 lbs (62.9kg)
Classics (Palazzo)	½" (13 mm)	30" (760 mm)	145" (3680 mm)	130.7 lbs (62.9kg)
Classics (Constellation)	½" (13 mm)	30" (760 mm)	145" (3680 mm)	130.7 lbs (62.9kg)
Brionne	½" (13 mm)	30" (760 mm)	145" (3680 mm)	130.7 lbs (62.9kg)
Bellissimo	½" (13 mm)	30" (760 mm)	145" (3680 mm)	130.7 lbs (62.9kg)



Spec Note: This product guide specification is written according to the Construction Specifications Institute (CSI) 3-Part Format, including MasterFormat™, SectionFormat™, and PageFormat™, as described in The Project Resource Manual—CSI Manual of Practice, Fifth Edition.

The section must be carefully reviewed and edited by the Architect to meet the requirements of the project and local building code. Coordinate this section with other specification sections and the drawings. Delete all “*Spec Notes*” after editing this section.

Section numbers are from MasterFormat 1995 Edition, with numbers from MasterFormat 2004 Edition in parentheses. Delete version not required.

Section 06610 (12 36 61.16)

Solid Surfacing Countertops

Spec Note: This section covers Hanwha Surfaces Hanex Solid Surfaces countertops. Consult Hanwha Surfaces for assistance in editing this section for the specific application.

– Part 1 General –

- 1.1 Section includes
 - A. Acrylic solid surfacing countertops.

Spec Note: Edit the following list of related sections as required for the project. List other sections with work directly related to this section.

- 1.2 Related sections
 - A. Section 06100 (06 10 00) - Rough Carpentry: Blocking and Supports
 - B. Section 06615 (06 61 16) - Solid Surfacing Fabrications
 - C. Section 07920 (07 92 00) - Joint Sealants
- 1.3 References
 - A. ANSI Z124 - Plastic Fixtures
 - B. ANSI/ICPA SS-1 - Performance Standard for Solid Surface Materials

Spec Note: List standards referenced in this section, complete with designations and titles. This article does not require compliance with standards, but is merely a listing of those used.



Product Guide Specifications

1.3 References continued

- C. ANSI/NEMA LD 3 - High Pressure Decorative Laminates
- D. ASTM D 256 - Standard Test Methods for Determining the Izod Pendulum Impact Resistance of Plastics
- E. ASTM D 570 - Standard Test Method for Water Absorption of Plastics
- F. ASTM D 638 - Standard Test Method for Tensile Properties of Plastics
- G. ASTM D 696 - Standard Test Method for Coefficient of Linear Thermal Expansion of Plastics Between -30° C and 30° C With a Vitreous Silica Dilatometer
- H. ASTM D 785 - Standard Test Method for Rockwell Hardness of Plastics and Electrical Insulating Materials
- I. ASTM D 790 - Standard Test Methods for Flexural Properties of Unreinforced and Reinforced Plastics and Electrical Insulating Materials
- J. ASTM D 1499 - Standard Practice for Filtered Open-Flame Carbon-Arc Exposures of Plastics
- K. ASTM D 2583 - Standard Test Method for Indentation Hardness of Rigid Plastics by Means of a Barcol Impressor
- L. NSF 51 - Food Equipment Materials

1.4 Submittals

- A. Comply with Section 01330 (01 33 00) - Submittal Procedures
- B. Product Data: Submit manufacturer's product data, including fabrication and installation instructions

Spec Note: Edit the following paragraph for shop drawings as required for the project.

- C. Shop Drawings: Submit fabricator/installer's shop drawings, including plans, elevations, sections, and details, indicating:
 - 1. Dimensions, tolerances, materials, components, attachments, fabrication, edge treatment, corners, location of seams, overhangs, backsplashes, and inlays
 - 2. Locations and sizes of cutouts and holes for items to be installed in countertops
 - 3. Locations and sizes of blocking, supports, and reinforcements to support countertops



Product Guide Specifications

- D. Samples: Submit manufacturer's samples of solid surfacing material in each color and finish.
- E. Manufacturer's Certification: Submit manufacturer's certification that solid surfacing material and adhesives comply with specified requirements.
- F. Fabricator/Installer's Certification: Submit fabricator/installer's certification by manufacturer.
- G. Care and Maintenance Instructions: Submit manufacturer's care and maintenance instructions, including cleaning and repairing instructions.
- H. Warranty: Submit manufacturer's standard warranty.

1.5 Quality Assurance

A. Fabricator/Installer's Qualifications:

1. Fabricator/installer regularly engaged, for preceding 5 years, in fabrication and installation of solid surfacing countertops of similar type to that specified.
2. Employ persons trained for fabrication and installation of solid surfacing countertops.
3. Certified by manufacturer to fabricate and install solid surfacing countertops.

Spec Note: Edit pre-installation meeting as required for the project. Delete if not required.

B. Pre-installation Meeting:

1. Schedule pre-installation meeting before start of installation of solid surfacing countertops.
2. Require attendance of parties directly affecting work of this section, including contractor, architect, fabricator/installer, and manufacturer's representative.
3. Review examination, installation, adjusting, cleaning, protection, and coordination with other work.

1.6 Delivery, Storage and Handling

A. Delivery:

1. Solid Surfacing Countertops: Deliver solid surfacing countertops to site in accordance with manufacturer's instructions.
2. Adhesives: Deliver adhesives to site in manufacturer's original, unopened containers and packaging, with labels clearly identifying product name and manufacturer.



Product Guide Specifications

B. Storage:

1. Solid surfacing countertops: Store vertically in clean, dry area indoors in accordance with manufacturer's instructions.
2. Adhesives:
 - a. Store adhesive tubes in upright position.
 - b. Store between 50° F and 70° F.

C. Handling:

1. Handle solid surfacing countertops in accordance with manufacturer's instructions.
2. Protect solid surfacing countertops during handling and installation from dirt, stains, cracks, scratches, and other damage.
3. Do not lay, transport, or carry solid surfacing countertops flat.
4. Do not drop or drag solid surfacing countertops.

1.7 Warranty

Spec Note: Specify warranty period. Consult Hanwha Surfaces for more information.

- A. Warranty Period: [Commercial 10-Year Limited Warranty] [Residential Lifetime Limited Warranty].

Spec Note: Edit the following article for extra materials as required for the project. Delete if extra materials are not required.

1.8 Extra Materials

- A. Deliver to owner minimum of [2] [_____] square feet of color-match solid surfacing material for each color specified.



– Part 2 Products –

2.1 Manufacturer

A. Hanwha L&C | Surfaces, 2839 Paces Ferry Road, Suite 200, Atlanta, GA 30339, 888.426.9421 or 770.431.6110, website: hanwhasurfaces.com, e-mail: info@hanwhasurfaces.com

2.2 Solid Surfacing Countertops

A. Solid Surfacing Countertops: Hanex Solid Surfaces

1. Conformance: ICPA SS-1
2. Certification: NSF 51 certified for food preparation area
3. Non-porous
4. Homogeneous
5. Solid and uniform throughout material thickness
6. Consistent color throughout material thickness

B. Composition:

1. Resins: Methyl Methacrylate (MMA) and Polymethyl Methacrylate (PMMA)
2. Filler: Alumina Trihydrate
3. Additives

C. Physical Properties:

1. Unit Weight: 1.8 g/cm³
2. Tensile Strength, ASTM D 638: 5,400 psi
3. Tensile Modulus, ASTM D 638: 1.4 x 10⁶ psi
4. Elongation, ASTM D 638: 0.42% minimum
5. Flexural Strength, ASTM D 790: 9,200 psi
6. Flexural Modulus, ASTM D 790: 1.34 x 10⁵ psi
7. Rockwell Hardness, ASTM D 785: 92.
8. Thermal Expansion, ASTM D 696: 3.04 x 10⁻⁵ in./in./° C
9. Gloss (60° Gardner), ANSI Z124: 5 to 75
10. Color Stability, NEMA LD 3: No change
11. Wear and Cleanability, ANSI Z124: Passes
12. Boiling Water Surface Resistance, NEMA LD 3: No change
13. High-Temperature Resistance, NEMA LD 3: No change
14. Stain Resistance, NEMA LD 3: Passes
15. Impact Resistance, NEMA LD 3: No fracture
16. IZOD Impact Strength, ASTM D 256: 0.28 foot-pounds/inch



Product Guide Specifications

17. Water Absorption Weight, ASTM D 570: 0.03% maximum
18. Fungi and Bacteria, ANSI Z124: No attack
19. Weatherability, ASTM D 1499: No change
20. Listed, NSF 51: All colors

D. Thickness: ½"

Spec Note: Specify solid surfacing countertop color. Consult Hanwha Surfaces for available colors.

E. Color: _____.

1. Solid surfacing countertops of same color from same production batch

Spec Note: Specify solid surfacing countertop finish. Consult Hanwha Surfaces for description of finishes.

F. Finish: [Matte] [Semi-gloss] [Gloss].

1. Uniform finish on exposed surfaces

Spec Note: Specify solid surfacing countertop edge treatment here or on the drawings. Consult Hanwha Surfaces for description of edge treatments.

G. Edge Treatment: [_____] [As indicated on the drawings].

Spec Note: Specify solid surfacing countertop backsplashes here or on the drawings. Consult Hanwha Surfaces for description of backsplashes. Delete if backsplashes are not required.

H. Backsplashes: [_____] [As indicated on the drawings].

1. Color: Same color from same production batch as countertops

Spec Note: Specify solid surfacing countertop inlays here or on the drawings. Consult Hanwha Surfaces for description of inlays. Delete if inlays are not required.

I. Inlays: [_____] [As indicated on the drawings].



2.3 Accessories

A. Adhesives: “Hanex Adhesive”.

1. Description: Two-component, solid surfacing adhesive.

- a. Working Time: 8 to 12 minutes at 72° F
- b. Full Cure: 12 hours at 72° F
- c. 100% reactive
- d. Translucent
- e. Readily accepts pigments for color matching
- f. UV stable
- g. Sandable
- h. Phthalate free
- i. Non yellowing
- j. Stain resistant
- k. Water penetration resistant, including boiling water

2. Physical Properties, Cured Adhesive:

- a. Tensile Strength, ASTM D 638: 3,850 psi
- b. Tensile Elongation: 6.9%
- c. Flexural Strength, ASTM D 790: 5,800 psi
- d. Impact Strength, NEMA LD 3: 4.6 foot-pounds
- e. Water Absorption, ASTM D 570: 0.26%
- f. Water Resistance, ICPA SS-1: 250 cycles
- g. Barcol Hardness, ASTM D 2583: 34/42

3. Color: Compatible with solid surfacing countertop color

B. Joint Sealants

1. 100% silicone
2. Compatible with solid surfacing countertops
3. As specified in Section 07920 (07 92 00)

2.4 Fabrication

A. Shop Assembly

1. Fabricate solid surfacing countertops in accordance with manufacturer's instructions
2. Fabricate solid surfacing countertops to greatest extent practical in shop



B. Seams:

1. Locate and fabricate seams in accordance with manufacturer's instructions.
2. Do not locate seams through cooktop cutouts.
3. Use manufacturer's adhesives.
4. Fabricate seams to be inconspicuous.

2.5 Source Quality Control

A. Visual Inspection of Solid Surfacing Countertops: Do not install solid surfacing countertops that do not pass visual inspection at fabricator/installer's shop.

1. Warping: Less than 1/6" per 10' of material
2. Foreign Particles: Less than 3 visible particles per sheet
3. Color Match: Same lot
4. White Spots: Less than 3 visible particles per sheet
5. Discoloration: None
6. Particle Distribution: Even distribution
7. Pit Holes: None
8. Uneven Sanding: None
9. Hairline Cracks: None
10. Concave: None

– Part 3 Execution –

3.1 Examination

- A. Examine areas to receive solid surfacing countertops.
- B. Verify surfaces to support solid surfacing countertops are clean, dry, flat, level, plumb, stable, rigid, and capable of handling the weight.
- C. Notify Architect of conditions that would adversely affect installation or subsequent use.
- D. Do not begin installation until unacceptable conditions are corrected.

3.2 Installation

- A. Install solid surfacing countertops in accordance with manufacturer's instructions at locations indicated on the drawings.
- B. Acclimate solid surfacing countertops to room temperature before installation.
- C. Install solid surfacing countertops level, plumb, square, true to line, and without warp.



Product Guide Specifications

- D. Install solid surfacing countertops securely in place with proper support at perimeter, seams, cutouts, overhangs, and other locations as required.
- E. Install solid surfacing countertops with 1/8" gap for every 10' of material when surface is enclosed between 2 walls or other obstructions.
- F. Ensure seams are inconspicuous.
- G. Sand and polish solid surfacing countertops in accordance with manufacturer's instructions to specified finish and to remove scratches.
- H. Ensure solid surfacing countertop installation is color matched.
- I. Do not install mechanical fasteners directly into solid surfacing countertops.
- J. Install joint sealants as specified in Section 07920 (07 92 00).

3.3 Adjusting

- A. Repair minor damages to finish in accordance with manufacturer's instructions and as approved by Architect.
- B. Remove and replace damaged solid surfacing countertops that cannot be successfully repaired, as determined by Architect.

3.4 Cleaning

- A. Clean solid surfacing countertops promptly after installation in accordance with manufacturer's instructions.
- B. Do not use harsh cleaning materials or methods that could damage finish.

3.5 Protection

- A. Protect installed solid surfacing countertops from dirt, stains, scratches, and damage during construction.
- B. Do not use installed solid surfacing countertops as work surfaces during construction.



Product Guide Specifications

Spec Note: This product guide specification is written according to the Construction Specifications Institute (CSI) 3-Part Format, including MasterFormat™, SectionFormat™, and PageFormat™, as described in the Project Resource Manual—CSI Manual of Practice, Fifth Edition.

The section must be carefully reviewed and edited by the Architect to meet the requirements of the project and local building code. Coordinate this section with other specification sections and the drawings. Delete all “*Spec Notes*” after editing this section.

Section numbers are from MasterFormat 1995 Edition, with numbers from MasterFormat 2004 Edition in parentheses. Delete version not required.

Section 06615 (06 61 16)

Solid Surfacing Fabrications

Spec Note: This section covers Hanwha Surfaces Hanex Solid Surfaces fabrications. Consult Hanwha Surfaces for assistance in editing this section for the specific application.

– Part 1 General –

1.1 Section Includes

A. Acrylic Solid Surfacing Fabrications:

Spec Note: List types of solid surfacing fabrications to be specified in this section. Edit the following list as required.

1. Wall coverings
2. Wainscoting
3. Partitions
4. Shower surrounds
5. Tub surrounds
6. Aprons
7. Window sills
8. Door sills
9. Thresholds
10. Signs
11. Name plates
12. Furniture
13. Shelves
14. _____
15. _____
16. _____



1.2 Related Sections

Spec Note: Edit the following list of related sections as required for the project. List other sections with work directly related to this section.

- A. Section 06100 (06 10 00) - Rough Carpentry: Blocking and Supports
- B. Section 06610 (12 36 61.16) - Solid Surfacing Countertops
- C. Section 07920 (07 92 00) - Joint Sealants

1.3 References

Spec Note: List standards referenced in this section, complete with designations and titles. This article does not require compliance with standards, but is merely a listing of those used.

- A. ANSI Z124 - Plastic Fixtures
- B. ANSI/ICPA SS-1 - Performance Standard for Solid Surface Materials
- C. ANSI/NEMA LD 3 - High Pressure Decorative Laminates
- D. ASTM D 256 - Standard Test Methods for Determining the Izod Pendulum Impact Resistance of Plastics
- E. ASTM D 570 - Standard Test Method for Water Absorption of Plastics
- F. ASTM D 638 - Standard Test Method for Tensile Properties of Plastics
- G. ASTM D 696 - Standard Test Method for Coefficient of Linear Thermal Expansion of Plastics Between -30° C and 30° C With a Vitreous Silica Dilatometer
- H. ASTM D 785 - Standard Test Method for Rockwell Hardness of Plastics and Electrical Insulating Materials
- I. ASTM D 790 - Standard Test Methods for Flexural Properties of Unreinforced and Reinforced Plastics and Electrical Insulating Materials
- J. ASTM D 1499 - Standard Practice for Filtered Open-Flame Carbon-Arc Exposures of Plastics
- K. ASTM D 2583 - Standard Test Method for Indentation Hardness of Rigid Plastics by Means of a Barcol Impressor
- L. NSF 51 - Food Equipment Materials

1.4 Submittals

- A. Comply with Section 01330 (01 33 00) - Submittal Procedures
- B. Product Data: Submit manufacturer's product data, including fabrication and installation instructions

Spec Note: Edit the following paragraph for shop drawings as required for the project.

- C. Shop Drawings: Submit fabricator/installer's shop drawings, including plans, elevations, sections, and details, indicating:
 - 1. Dimensions, tolerances, materials, components, attachments, fabrication, edge treatment, corners, location of seams, overhangs, and inlays



Product Guide Specifications

2. Locations and sizes of cutouts and holes for items to be installed in fabrications
 3. Locations and sizes of blocking, supports, and reinforcements to support fabrications
 - D. Samples: Submit manufacturer's samples of solid surfacing material in each color and finish
 - E. Manufacturer's Certification: Submit manufacturer's certification that solid surfacing material and adhesives comply with specified requirements.
 - F. Fabricator/Installer's Certification: Submit fabricator/installer's certification by manufacturer
 - G. Care and Maintenance Instructions: Submit manufacturer's care and maintenance instructions, including cleaning and repairing instructions.
 - H. Warranty: Submit manufacturer's standard warranty
- 1.5 Quality Assurance
- A. Fabricator/Installer's Qualifications:
 1. Fabricator/installer regularly engaged, for preceding 5 years, in fabrication and installation of solid surfacing fabrications of similar type to that specified
 2. Employ persons trained for fabrication and installation of solid surfacing fabrications
 3. Certified by manufacturer to fabricate and install solid surfacing fabrications

Spec Note: Edit pre-installation meeting as required for the project. Delete if not required.



B. Pre-installation Meeting:

1. Schedule pre-installation meeting before start of installation of solid surfacing fabrications.
2. Require attendance of parties directly affecting work of this section, including Contractor, Architect, fabricator/installer, and manufacturer's representative.
3. Review examination, installation, adjusting, cleaning, protection, and coordination with other work.

1.6 Delivery, Storage and Handling

A. Delivery:

1. Solid Surfacing fabrications: Deliver solid surfacing fabrications to site in accordance with manufacturer's instructions.
2. Adhesives: Deliver adhesives to site in manufacturer's original, unopened containers and packaging, with labels clearly identifying product name and manufacturer.

B. Storage:

1. Solid Surfacing Fabrications: Store vertically in clean, dry area indoors in accordance with manufacturer's instructions.
2. Adhesives:
 - a. Store adhesive tubes in upright position.
 - b. Store between 50° F and 70° F.

C. Handling:

1. Handle solid surfacing fabrications in accordance with manufacturer's instructions.
2. Protect solid surfacing fabrications during handling and installation from dirt, stains, cracks, scratches, and other damage.
3. Do not lay, transport, or carry solid surfacing fabrications flat.
4. Do not drop or drag solid surfacing fabrications.

1.7 Warranty

Spec Note: Specify warranty period. Consult Hanwha Surfaces for more information.

- A. Warranty period: [Commercial 10-Year Limited Warranty] [Residential Lifetime Limited Warranty].

Spec Note: Edit the following article for extra materials as required for the project. Delete if extra materials are not required.

1.8 Extra Materials

- A. Deliver to owner minimum of [2] [_____] square feet of color-match solid surfacing material for each color specified.



– Part 2 Products –

2.1 Manufacturer

A. Hanwha L&C | Surfaces, 2839 Paces Ferry Road, Suite 200, Atlanta, GA 30339, 888.426.9421 or 770.431.6110, website: hanwhasurfaces.com, e-mail: info@hanwhasurfaces.com

2.2 Solid Surfacing Fabrications

A. Solid Surfacing Fabrications: Hanex Solid Surfaces

1. Conformance: ICPA SS-1
2. Certification: NSF 51 certified for food preparation area
3. Non-porous
4. Homogeneous
5. Solid and uniform throughout material thickness
6. Consistent color throughout material thickness

B. Composition:

1. Resins: Methyl Methacrylate (MMA) and Polymethyl Methacrylate (PMMA)
2. Filler: Alumina Trihydrate
3. Additives

C. Physical Properties:

1. Unit Weight: 1.8 g/cm³
2. Tensile Strength, ASTM D 638: 5,400 psi
3. Tensile Modulus, ASTM D 638: 1.4 x 10⁶ psi
4. Elongation, ASTM D 638: 0.42% minimum
5. Flexural Strength, ASTM D 790: 9,200 psi
6. Flexural Modulus, ASTM D 790: 1.34 x 10⁵ psi
7. Rockwell Hardness, ASTM D 785: 92
8. Thermal Expansion, ASTM D 696: 3.04 x 10⁻⁵ in./in./° C
9. Gloss (60° Gardner), ANSI Z124: 5 to 75
10. Color Stability, NEMA LD 3: No change
11. Wear and Cleanability, ANSI Z124: Passes
12. Boiling Water Surface Resistance, NEMA LD 3: No change
13. High-Temperature Resistance, NEMA LD 3: No change
14. Stain Resistance, NEMA LD 3: Passes
15. Impact Resistance, NEMA LD 3: No fracture
16. IZOD Impact Strength, ASTM D 256: 0.28 foot-pounds/inch
17. Water Absorption Weight, ASTM D 570: 0.03% maximum
18. Fungi and Bacteria, ANSI Z124: No attack
19. Weatherability, ASTM D 1499: No change
20. Listed, NSF 51: All colors

Spec Note: Specify solid surfacing fabrication thickness.



Product Guide Specifications

D. Thickness:

1. Vertical Applications: ¼"
2. Horizontal Applications: ½"

Spec Note: Specify solid surfacing fabrication color. Consult Hanwha Surfaces for available colors.

E. Color: _____.

1. Solid surfacing fabrications of same color from same production batch

Spec Note: Specify solid surfacing fabrication finish. Consult Hanwha Surfaces for description of finishes.

F. Finish: [Matte] [Semi-gloss] [Gloss]

1. Uniform finish on exposed surfaces

Spec Note: Specify solid surfacing fabrication edge treatment here or on the drawings. Consult Hanwha Surfaces for description of edge treatments.

G. Edge Treatment: [_____] [As indicated on the drawings].

Spec Note: Specify solid surfacing fabrication inlays here or on the drawings. Consult Hanwha Surfaces for description of inlays. Delete if inlays are not required.

H. Inlays: [_____] [As indicated on the drawings].



2.3 Accessories

A. Adhesives: “Hanex Adhesive”

1. Description: Two-component, solid surfacing adhesive
 - a. Working Time: 8 to 12 minutes at 72° F
 - b. Full Cure: 12 hours at 72° F
 - c. 100% reactive
 - d. Translucent
 - e. Readily accepts pigments for color matching
 - f. UV stable
 - g. Sandable
 - h. Phthalate free
 - i. Non-yellowing
 - j. Stain resistant
 - k. Water penetration resistant, including boiling water
2. Physical Properties, cured adhesive:
 - a. Tensile Strength, ASTM D 638: 3,850 psi
 - b. Tensile Elongation: 6.9%
 - c. Flexural Strength, ASTM D 790: 5,800 psi
 - d. Impact Strength, NEMA LD 3: 4.6 foot-pounds
 - e. Water Absorption, ASTM D 570: 0.26%
 - f. Water Resistance, ICPA SS-1: 250 cycles
 - g. Barcol Hardness, ASTM D 2583: 34/42
3. Color: Compatible with solid surfacing fabrications color

B. Joint Sealants:

1. 100% silicone
2. Compatible with solid surfacing fabrications
3. As specified in Section 07920 (07 92 00)

2.4 Fabrication

A. Shop Assembly:

1. Fabricate solid surfacing fabrications in accordance with manufacturer's instructions.
2. Fabricate solid surfacing fabrications to greatest extent practical in shop.



B. Seams:

1. Locate and fabricate seams in accordance with manufacturer's instructions.
2. Use manufacturer's adhesives.
3. Fabricate seams to be inconspicuous.

2.5 Source Quality Control

A. Visual Inspection of Solid Surfacing Fabrications: Do not install solid surfacing fabrications that do not pass visual inspection at Fabricator/Installer's shop.

1. Warping: Less than 1/6" per 10' of material
2. Foreign Particles: Less than 3 visible particles per sheet
3. Color Match: Same lot
4. White Spots: Less than 3 visible particles per sheet
5. Discoloration: None
6. Particle Distribution: Even distribution
7. Pit Holes: None
8. Uneven Sanding: None
9. Hairline Cracks: None
10. Concave: None

– Part 3 Executions –

3.1 Examination

- A. Examine areas to receive solid surfacing fabrications.
- B. Verify surfaces to support solid surfacing fabrications are clean, dry, flat, level, plumb, stable, rigid, and capable of handling the weight.
- C. Notify Architect of conditions that would adversely affect installation or subsequent use.
- D. Do not begin installation until unacceptable conditions are corrected.

3.2 Installation

- A. Install solid surfacing fabrications in accordance with manufacturer's instructions at locations indicated on the drawings.
- B. Acclimate solid surfacing fabrications to room temperature before installation.
- C. Install solid surfacing fabrications level, plumb, square, true to line, and without warp.



Product Guide Specifications

- D. Install solid surfacing fabrications securely in place with proper support at perimeter, seams, cutouts, overhangs, and other locations as required.
- E. Install solid surfacing fabrications with 18" gap for every 10' of material when surface is enclosed between 2 walls or other obstructions.
- F. Ensure seams are inconspicuous.
- G. Sand and polish solid surfacing fabrications in accordance with manufacturer's instructions to specified finish and to remove scratches.
- H. Ensure solid surfacing fabrication installation is color matched.
- I. Do not install mechanical fasteners directly into solid surfacing fabrications.
- J. Install joint sealants as specified in Section 07920 (07 92 00).

3.3 Adjusting

- A. Repair minor damages to finish in accordance with manufacturer's instructions and as approved by architect.
- B. Remove and replace damaged solid surfacing fabrications that cannot be successfully repaired, as determined by architect.

3.4 Cleaning

- A. Clean solid surfacing fabrications promptly after installation in accordance with manufacturer's instructions.
- B. Do not use harsh cleaning materials or methods that could damage finish.

3.5 Protection

- A. Protect installed solid surfacing fabrications from dirt, stains, cracks, scratches, and other damage during construction.
- B. Do not use installed solid surfacing fabrications as work surfaces during construction.



1. Basic Composition

Hanex Solid Surfaces are made with a composition of Methyl Methacrylate (MMA) and Poly Methyl Methacrylate (PMMA) resin filled with Alumina Trihydrate and other specialized formula to give them the timeless beauty and quality. Hanwha Surfaces is one of only two companies to have successfully developed the DBCU (Double Belt Casting Unit) process to produce superior products.

<i>Material Name</i>	<i>Component</i>
MMA (Methyl Methacrylate)	Resin
PMMA (Polymethyl Methacrylate)	Resin
AL (OH) 3 – Alumina Trihydrate	Filler
Cross Linking Agents, Stabilizers, Curing Agents, Pigments, etc.	Additives

*This technical information is designed to provide support in fabrication, installation and/or to ensure performance of Hanex Solid Surfaces. The information is based on the technical data which Hanwha Surfaces believes to be reliable and is intended for person or persons having knowledge of this technical area. None of the contents, including but not limited to the instructions, recommendations, graphics, techniques and guidelines should be understood as implying of legal warranty or any type of liability by Hanwha Surfaces and its affiliates.



2. Technical Data Sheet

<i>Properties</i>	<i>Unit</i>	<i>Result</i>	<i>Test Standard</i>
Specific Gravity	g/cm ³	1.8	
Tensile Strength	psi	5,400	ASTM D 638
Tensile Modulus	psi	1.4x10 ⁶	ASTM D 638
Elongation	% min	0.42	ASTM D 638
Flexural Strength	psi	9,200	ASTM D 790
Flexural Modulus	psi	1.38x10 ⁵	ASTM D 790
Hardness (Rockwell)		92	ASTM D 785
Thermal Expansion	mm/mc	3.04x10 ⁻⁵	ASTM D 785
Gloss (60° Gardner)		5 ~ 20	ANSI Z124
Color Stability		No change	NEMA LD3
Wear & Cleanability		Passes	ANSI Z124
Boiling Water Surface Resistance		No change	NEMA LD3
High Temperature Resistance		No change	NEMA LD3
Stain Resistance		Passes	NEMA LD3
Impact Resistance		No fracture	NEMA LD3
IZOD Impact Strength	ft.lbs/in	0.28	ASTM D256
Water Absorption Weight	% max	0.03	ASTM D 570
Fungi & Bacteria		No attack	ANSI Z124
Wetherability		No change	ASTM D 1499
NSF 51	Listed	All Colors	NSF



3. Fungal Resistance Test Result

- Test Method:
 - ASTM G 21
(Determining Resistance of Synthetic Polymeric Material to Fungi)
 - Test Organism
 - Aspergillus Niger (ATCC 9642)
 - Chaetomium Globosum (ATCC 6205)
 - Penicillium Pinophilum (ATCC 11797)
 - Gliocladium Virens (ATCC 9645)
 - Aureobasidium Pullulans (ATCC 15233)
 - Rating in Accordance to ASTM G 21

<i>Rating</i>	<i>Growth Ratio</i>
0	None (No Growth)
1	Trace of Growth (Less than 10%)
2	Light Growth (10% - 30%)
3	Medium Growth (30% - 60%)
4	Heavy Growth (60% - Complete Coverage)

- Test Result:
Zero traces of growth

<i>Culture Time</i>	<i>Week 1</i>	<i>Week 2</i>	<i>Week 3</i>
Result	0	0	0



4. Bacterial Resistance Test Result

- Test Method:
 - ASTM G22
(Determining Resistance of Plastics to Bacteria)
 - Test Organism
Pseudomonas Aeruginosa (ATCC 13388)
 - Rating in Accordance to ASTM G 22

<i>Rating</i>	<i>Growth Ratio</i>
0	None (No Growth)
1	Trace of Growth (Less than 10%)
2	Light Growth (10% - 30%)
3	Medium Growth (30% - 60%)
4	Heavy Growth (60% - Complete Coverage)

- Test Result:
Zero traces of growth

<i>Culture Time</i>	<i>Week 1</i>	<i>Week 2</i>	<i>Week 3</i>
Result	0	0	0



5. Flammability

- Test Method:

- ASTM Designation E 84-01:

(Standard Method of Test for Surface Burning Characteristics of Building Materials)

The test procedure is comparable to UL 723, ANSI/NFPA No. 255, and UBC No. 8-1

- Sample Presentation:

The sample materials were submitted in six pieces 24" wide by 48" long.

The test was conducted in three different thickness:

(6mm = ¼")

(9mm = 3⁄8")

(12mm = ½")

- Sample Conditioning:

Prior to testing, the sample pieces were placed in the conditioning room (maintained at 73.4 +/- 5° F and relative humidity of 50 +/- 5%) for a period of no less than 28 days and no more than 33 days.

- Rating (Building Codes Cited):

National Fire Protection Association, ANSI/NFPA No. 101, "Life Safety Code"

Uniform Building Code, Interior Finishes, Sections 801-807

<i>NFPA</i>	<i>UBC</i>	<i>Flame Spread</i>	<i>Smoke Development</i>
Class A	Class I	0 - 25	0 - 450
Class B	Class II	25 - 72	0 - 450
Class C	Class III	76 - 200	0 - 450



Technical Information

- Test Result:

Because of the possible variations in reproducibility, the results are adjusted to the nearest figure divisible by 5. In order to obtain the Flame Spread Classification, the Test Result should be compared to the NFPA Class and UBC Class listed in Page 28.

<i>Thickness</i>	<i>Flame Spread</i>	<i>Smoke Density</i>	<i>Rating</i>
6mm (¼")	5	0	Class A / Class I
9mm (3/8")	5	5	Class A / Class I
12mm (½")	0	0	Class A / Class I

- Reference Table:

<i>Item</i>	<i>Flame Spread</i>	<i>Smoke Development</i>
Gypsum	15	0
Acoustic Tiles	25	10
Interior Wall Covering	25	15
Laminates (Plastic)	70	35
Fiberglass Reinforced Panels	70	500+
Hardboard	150	400
Wood Particle Board	1155	200

*This technical information is designed to provide support in fabrication, installation and/or to ensure performance of Hanex Solid Surfaces. The information is based on the technical data which Hanwha Surfaces believes to be reliable and is intended for person or persons having knowledge of this technical area. None of the contents, including but not limited to the instructions, recommendations, graphics, techniques and guidelines should be understood as implying of legal warranty or any type of liability by Hanwha Surfaces and its affiliates.



6. Chemical and Stain Performance and Report

- Test Method:
 - The chemical and stain reagents were applied to the surface and exposed to the sample of Hanex Solid Surfaces for 16 hours.
 - The stained samples were then cleaned with a household cleanser and wet scrubbing pads.
 - The stained samples were covered with a glass plate for adequate coverage.

<i>Classification</i>	<i>%</i>	<i>Gritty Cleaner or Water</i>	<i>Scotch Brite™ or Sand Paper</i>
Acetic Acid	5	✓	
Acetic Acid	10	✓	
Acetic Acid	90		✓
Acetic Acid	98		✓
Acetone		✓	
Aqua Regia			✓
Ammonia	10	✓	
Ammonium Hydroxide	5	✓	
Ammonium Hydroxide	28	✓	
Benzene		✓	
Calcium Thiocyanate	78	✓	
Chloric Hydroxide	20		✓
Chloroform	100		✓
Citric Acid	10	✓	
Dimethyl Formamide		✓	

*This technical information is designed to provide support in fabrication, installation and/or to ensure performance of Hanex Solid Surfaces. The information is based on the technical data which Hanwha Surfaces believes to be reliable and is intended for person or persons having knowledge of this technical area. None of the contents, including but not limited to the instructions, recommendations, graphics, techniques and guidelines should be understood as implying of legal warranty or any type of liability by Hanwha Surfaces and its affiliates.



Technical Information

<i>Classification</i>	<i>%</i>	<i>Gritty Cleaner or Water</i>	<i>Scotch Brite™ or Sand Paper</i>
Ethanol	95	✓	
Ethyl Ether		✓	
Formic Acid	88		✓
Formaldehyde		✓	
Furfural			✓
Gasoline		✓	
Hydrochloric Acid	10	✓	
Hydrochloric Acid	20	✓	
Hydrochloric Acid	37	✓	
Isopropyl Alcohol		✓	
Kerosene	20	✓	
Methyl Alcohol	5	✓	
Methyl Ethyl Ketone		✓	
Mineral Oil		✓	
Nitric Acid	10		✓
Nitric Acid	30		✓
Nitric Acid	40		✓
Nitric Acid	70		✓
Phenol	40		✓
Phenol	85		✓
Phosphoric Acid	25		✓
Phosphoric Acid	85		✓
Silver Nitrate	10	✓	
Sodium Hydroxide	10	✓	
Sodium Hydroxide	25	✓	
Sodium Hydroxide	40	✓	

*This technical information is designed to provide support in fabrication, installation and/or to ensure performance of Hanex Solid Surfaces. The information is based on the technical data which Hanwha Surfaces believes to be reliable and is intended for person or persons having knowledge of this technical area. None of the contents, including but not limited to the instructions, recommendations, graphics, techniques and guidelines should be understood as implying of legal warranty or any type of liability by Hanwha Surfaces and its affiliates.



Technical Information

Classification	%	Gritty Cleaner or Water	Scotch Brite™ or Sand Paper
Sodium Hypochlorite		✓	
Sodium Sulphate		✓	
Sulphuric Acid		✓	
Sulphuric Acid		✓	
Sulphuric Acid			✓
Sulphuric Acid			✓
Toluene			✓
Xylene		✓	
Zinc Chloride		✓	

Supplementary Notes:

- For exposures to chemicals other than above, it is recommended to test on a sample piece of Hanex Solid Surfaces to confirm suitability for application.
- Some chemical reagents may damage the surface more seriously and will require expert repair or replacement.
- Common domestic residues, such as the examples listed below, can be removed with water and household cleaners.

Alcohol	Cigarette stain	Cooking oil	Curry powder
Hair dyes	Lipsticks	Mustard	Pencil lead
Shoe polish	Sugar	Tomato sauce	Wine
Ink	Coffee	Crayon	Make-up
Juices	Lotions	Nail polish	Salt
Soy sauce	Tea	Vinegar	Food dyes

*This technical information is designed to provide support in fabrication, installation and/or to ensure performance of Hanex Solid Surfaces. The information is based on the technical data which Hanwha Surfaces believes to be reliable and is intended for person or persons having knowledge of this technical area. None of the contents, including but not limited to the instructions, recommendations, graphics, techniques and guidelines should be understood as implying of legal warranty or any type of liability by Hanwha Surfaces and its affiliates.



7. High-Temperature Resistance

- Test Method:

- ANSI/NEMA LD 3-2000, Section 3.6

- Sample Preparation:

All samples were prepared by sanding the surface as in an actual installation.

Step 1: Sanded with 100 micron grit, three passes over substrate

Step 2: Sand with 60 micron grit, three passes over substrate

Step 3: Sand with maroon Scotch Brite™ pad, 2 passes over substrate

Step 4: Sand with gray Scotch Brite™ pad, 2 passes over substrate

Scotch Brite™ is a trademark of 3M Company, USA

- Sample Conditioning:

Prior to testing, the sample pieces were placed in the conditioning room (maintained at 74 ± 5° F and relative humidity of 53% ± 5%) for a period no less than 48 hours.

- Test Procedure:

A heating vessel was filled ¾ full of paraffin wax and heated to 365° F and then allowed to cool to 356° F. The vessel was then placed on the sample for 20 minutes, then removed. A visual examination was then performed 24 hours after the removal of the vessel. Viewing was performed at a distance of approximately 30" - 36" and an angle of approximately 45° to 75° from the table surface. The samples were rotated on the same plane and viewed from all directions.

- Test Result:

From four samples that were tested, three sample pieces had no effect (no change in color or surface finish). One sample did have a slight effect (change in color of surface finish that is only visible at certain angles of direction). Standard repair techniques were used to correct any discoloration.



8. Color Fastness and Aging

- Test Method:

- ANSI/ICPA SS-12001, ASTM D 2565 and NEMA LD 3-2000

- Sample Preparation:

Three 2" x 5" along with one additional sample was retained for control sample.

All samples were prepared by sanding the surface as in an actual installation.

Step 1: Sanded with 100 micron grit, three passes over substrate

Step 2: Sand with 60 micron grit, three passes over substrate

Step 3: Sand with maroon Scotch Brite™ pad, 2 passes over substrate

Step 4: Sand with gray Scotch Brite™ pad, 2 passes over substrate

Scotch Brite™ is a trademark of 3M Company, USA

- Sample Conditioning:

Prior to testing, the sample pieces were placed in the conditioning room (maintained at 74 ± 5° F and relative humidity of 53% ± 5%) for a period no less than 48 hours.

- Test Procedure:

The samples were placed into a Xenon Arc test chamber for 200 hours. The black panel temperature was 145° F and the irradiance set to 0.35W/m² @ 340nm. At the completion of the test, the control sample was visually compared to the tested samples and performed at a distance of approximately 30" - 36" and an angle of approximately 45° to 75° from the table surface. The samples were rotated on the same plane and viewed from all directions.

- Test Result:

From four samples that were tested, three sample pieces had no effect (no change in color or surface finish). One sample did have slight effect (change in color of surface finish that is only visible at certain angles of direction). Standard repair techniques were used to correct any discoloration.



9. Thermoforming

- Among the many benefits of Hanex Solid Surfaces over other surfacing materials, the ability to thermoform allows unlimited design possibilities. To achieve the proper result, right oven calibration, minimum radius and accurate mold preparation are important.
- Recommended minimum radius depending on thickness and color group

<i>Sheet Thickness</i>	<i>Maximum Inside Radius</i>	<i>Material Grade</i>
¼" Material	1" Radius	Solo, Duo
½" Material	3" Radius	Solo, Duo
½" Material	5" Radius	Trio
½" Material	7" Radius	Palazzo

- Recommended heat and duration depending on thickness

<i>Sheet Thickness</i>	<i>Oven Temperature</i>	<i>Time</i>
¼" Material	150° C (302° F)	30 - 60 min
	175° C (347° F)	15 - 30 min
½" Material	150° C (302° F)	45 - 80 min
	175° C (347° F)	25 - 60 min

*This technical information is designed to provide support in fabrication, installation and/or to ensure performance of Hanex Solid Surfaces. The information is based on the technical data which Hanwha Surfaces believes to be reliable and is intended for person or persons having knowledge of this technical area. None of the contents, including but not limited to the instructions, recommendations, graphics, techniques and guidelines should be understood as implying of legal warranty or any type of liability by Hanwha Surfaces and its affiliates.



Material Safety Data Sheet

Product Name

Hanex Solid Surfaces (Hanex[®] is a registered trademark of Hanwha L&C Corporation)

Manufacturer/supplier

Hanwha Living and Creative Corporation
 Hanwha Building
 1 Changgyo-dong, Chung-gu
 Seoul, Korea
 Tel: 82.2.729.2051
 Fax: 82.2.729.1447

Contact For Product Information or Emergency

Hanwha Surfaces
 2839 Paces Ferry Rd, Suite 200
 Atlanta, GA 30339
 Tel: 888.426.9421
 Tel: 770.431.6110

Composition/information on Ingredients

Component	Case #	% by Weight
Polymethyl methacrylate	8011-14-7	>30
Almina Trihydrate	21645-51-2	<70
Methyl Methacrylate (Degradation product)	80-62-6 <1	<1

Heated above 300°C, Hanex Solid Surfaces can release

Fire-Fighting Measures and Explosion Hazard

- Flammable Properties
 - Hanex Solid Surfaces can be combusted only with difficulty.
 - Hazardous gases/vapor produced in fire are carbon monoxide, methyl methacrylate, aldehydes.
- Extinguishing Media
 - Water, Dry Chemical, CO₂
- Fire-Fighting Instructions
 - Keep personnel removed and upwind of fire.
 - Wear self-contained breathing apparatus.



Material Safety Data Sheet

Accidental Release Measures

- Safeguard (Personnel)
 - Use appropriate personal protective during clean up.
 - Note:* Review Fire-Fighting Measures and Handling (Personnel) sections before proceeding with clean-up.
- Spill Clean-Up
 - Recover undamaged and minimally contaminated material for reuse and reclamation.

Handling and storage

- Handling (Personnel):
 - Avoid breathing dust.
 - Avoid breathing fumes generated during sawing, routing or drilling.
- Handling (Physical Aspects):
 - Avoid dust generation.
- Storage
 - Store in a cool place.

Exposure Controls and Personal Protection

- Engineering Controls (Ventilation):
 - Use ventilation that is adequate to keep employee exposure to airborne concentration below exposure limits.
- Personal Protection
 - Protective equipment: Eye/Face protection
 - Wear safety glasses during operations such as sawing, sanding, drilling or routing.



Toxicological Information

- Skin/Eye Irritant:
 - Polymethyl Methacrylate
The compound is not a skin or eye irritant and is not a skin sensitizer in animals. Single or repeated ingestion produced mild degenerative changes of liver and kidney.
 - Methyl Methacrylate
The compound is a skin irritant, is a moderate eye irritant and is a skin sensitizer in animals.
 - Alumina Trihydrate
The compound is untested for skin and eye irritant and is untested for animal sensitization.
 - Acute Toxicity (LC50):
 - Polymethyl Methacrylate: >2MG/1, 4hr LC50 (Inhalation/Rat)
 - Methyl Methacrylate: 7093PPM/4 hr LC50 (Inhalation/Rat)
 - Acute Toxicity (LD50):
 - Polymethyl Methacrylate: >2000mg/kg, 4hr LD50 (Oral/Cat)
 - Methyl Methacrylate: 7900PPM/4 hr LD50 (Oral/Cat)

Ecological Information

- Biodegradation: No information available.
- Bioaccumulation: No information available.
- Aquatic Toxicity: No information available.

Disposal Considerations

- Dispose in accordance with federal, state and local regulation.
- The owner of the material is responsible for proper waste disposal.



Material Safety Data Sheet

Other Information

- The data in this Material Safety Data Sheet relates only to the specific material designated herein and does not relate to use in combination with any other material or in any process.
- Responsibility for MSDS: Hanex Solid Surfaces products
- This information is based on technical information deemed reliable and is subject to revision as additional information is made available.

Components Material

- Methyl Methacrylate (MMA)
- Polymethyl Methacrylate (PMMA)
- Unsaturated Polyester Resin (UPR)
- Aluminum Trihydrate (AL-OH₃)

Materials are not known to contain toxic materials under Title III and Reauthorization Act of 1986 and 40 CFR part 372.

Hazards Identification

- Xacrylon Solid Surface is not hazardous in its original state but fabricating procedures may generate dust at a high degree, which might result in release of MMA vapor that could cause irritation to the eye, nose and throat areas and skin rash. Inhalation of MMA vapor may cause nausea, shortness of breath, coughing, lung irritation, increased blood pressure and abnormal testing of kidney functions.
- Persons with lung disease may have adverse affects when exposed to dust of MMA.
- There are no known carcinogens in this material at levels in excess of .1%, as listed by OSHA or IARC.

First Aid Measures

- Inhalation – No specific action required. If any irritation occurs, consult a physician.
- Eye Contact – Flush eyes immediately with ample amounts of fresh water for at least 20 minutes. Consult a physician.
- Ingestion – Although the material is unlikely to be hazardous after ingestion, consult a physician.



Material Safety Data Sheet

Fire-Fighting Measures

Pursuant to NEMA LD3, Xacrylon is highly resistant to flame, but if exposed to extremely high temperatures it may be combusted. Hazardous gases released in fire are methyl methacrylate, carbon monoxide and aldehydes. Agents for extinguishing are water, dry chemical and carbon dioxide. Instructions for fire-fighting are to keep personnel upwind and to wear self-contained breathing equipment.

Storage and Handling

- Avoid breathing dust or creating dust.
- Work areas should be clean, dry and well ventilated.
- Work gloves, work shoes and protective eye goggles should be worn.
- A protective face dust mask should be used over nose and mouth when engaging power tools.
- Avoid breathing fumes as a result of fabrication.
- Store in a dry and cool place.

Physical and Chemical Properties

- 0% Volatiles
- Insoluble in water
- Form – sheets
- Specific Gravity – 1.8 g/cm³

Chemical Stability

- Stable at normal temperatures and storage
- Decomposition at 572°F. Release of MMA
- Will not polymerize

Waste Disposal

Incineration or use of landfill

Regulatory Information

No known substances to cause cancer, birth defects or other reproductive injury.



Unlike other surfacing materials which are produced by laminating or coating, Hanex Solid Surfaces are non-porous and solid throughout the entire material. These features make Hanex Solid Surfaces virtually maintenance-free and repairable. To ensure long-lasting beauty, follow these guidelines to prevent damages and to take care of your investment.

Everyday Cleaning

- Wipe clean with a damp cloth or sponge.
- Basic stains: Clean with mild detergents or general purpose cleaners.
- Periodically go over surface with a mild abrasive cleanser or wet white Scotch Brite™ pad to maintain a uniform appearance.

Heat Damage

The innate feature of Hanex Solid Surfaces gives it excellent heat-resistant properties compared to other surfacing materials in the market. However, to prevent any damages from heat, never place hot items directly on the countertop. Remember, placing hot pans or heat-generating appliances directly on Hanex Solid Surfaces may cause damage to your countertop. Avoid direct and indirect heat with temperatures over 80°C (170°F).

Chemical Damages

Avoid contact with strong chemicals that can cause damage to your surface such as oven cleaners, acetone, paint removers and others. If exposed, promptly flush with water. Remember, prolonged contact with harsh chemicals can cause serious damage to your Hanex Solid Surfaces.

Simple Steps to Avoid Damage

- Avoid cutting directly on Hanex Solid Surfaces, use a cutting board.
- Never place hot pans directly on the countertop. Even though Hanex Solid Surfaces can withstand temperatures up to 350°F, prolonged or extreme heat could cause permanent damage.
- Strong acids, such as those found in drain cleaners should be flushed with water immediately. Some of these items, when left on the surface may cause whitening, which can be difficult to remove.



Removing Persistent Stains

- To remove persistent stains, cigarette burns or scratches: Scrub with an abrasive cleanser and green Scotch Brite™ pad.
- Deep scratches can be removed by carefully sanding lightly with 120 grit sandpaper, followed by 220 grit and finishing with 320 grit sandpaper. Complete by rubbing the surface with a wet green Scotch Brite™ pad in a circular motion to restore the finish.

Note: Different methods can be used depending on the finish.

- For deep scratches and/or damages which may require expert repair, please contact your Authorized Hanex Solid Surfaces Repair Agent or Certified Hanex Solid Surfaces Fabricator.



Residential Lifetime Limited Warranty for North America

Hanwha L&C Corporation (hereunder “Hanwha”) warrants to the original purchaser/owner in the U.S. and Canada that its product Hanex Solid Surfaces, shall be free from manufacturing defects in material under normal use and service. Hanwha, at its discretion, will repair or replace product failures only due to manufacturing defects.

This Lifetime Limited Warranty is available only to the original owner(s) of the residence in which Hanex Solid Surfaces has been originally installed. The Lifetime Limited Warranty is non transferrable and applies to Hanex Solid Surfaces product only, for interior, residential application(s) in North America. This warranty is void unless the product has been paid for in full, and the product must be registered on or before 30 days of installation.

Under this Lifetime Limited Warranty, Hanwha’s authorized agents must be permitted sufficient time and opportunity to inspect the Product(s), evaluate and respond to any claim. All decisions regarding the existence of manufacturing defects or affecting this warranty shall be made by Hanwha and shall be final and binding upon all parties.

The professional fabricator/installer is responsible to inspect the Hanex Solid Surfaces material before fabricating and/or installing the Hanex Solid Surfaces product. It is also the end user’s responsibility to inspect the finished product before permanent installation. This warranty does not cover any defects that were visible at the time of fabrication/installation and were not avoided during fabrication/installation. All parties must agree to comply with the terms and conditions outlined in this Lifetime Limited Warranty.

This Lifetime Limited Warranty applies to product(s) that was installed after January 1, 2010.

Exclusions for Hanex Solid Surfaces Lifetime Limited Warranty:

1. Any residence where the original purchaser is not the occupant.
2. Materials and/or services that have not been paid in full.
3. Failure to comply with Hanwha’s recommended storage, handling, fabrication and installation and Care & Maintenance guidelines.
4. Damage caused by accidents, abuse, and/or misuse.
5. Acts of Mother Nature.
6. Improper workmanship of fabrication and/or installation.
7. Exposure to extreme heat; a trivet is always recommend for the use of your Hanex Solid Surfaces.
8. Installed Hanex Solid Surfaces product that is removed from their original place of installation or alteration/repair performed on product by one other than Certified Hanex Solid Surfaces fabricator/installer.
9. Product(s) installed in any outdoor application.
10. Color variation from samples.
11. Failure caused by inadequate support or structural movement.
12. Exposure to harsh or corrosive chemicals and cleaners.
13. Excessive weight placed on Hanex Solid Surfaces.



Residential Warranties

14. Appearance of edges, joints or seams due to improper fabrication/installation. Appearance of grout and/or caulk is not covered under warranty.
15. Supplemental repairs including, but not limited to, plumbing modifications, electrical, tile, cabinetry, flooring, backsplashes etc that may be necessary to repair or replace the Hanex Solid Surfaces under this warranty.
16. Minor conditions such as scratches, stains, water spots, and burns, which may be corrected by Hanex Solid Surfaces Care & Maintenance instructions/guidelines.

When choosing a color, please refer to samples only as a general indication of a particular color's design pattern, aesthetics, and hue. Samples are not guaranteed to be an exact replica of Hanex Solid Surfaces sheets and may vary from the actual, installed Hanex Solid Surfaces.

No other warranties express or implied, are made, including merchantability or fitness for a particular purpose. Except as provided herein, Hanwha is not liable in tort or contract for any loss of direct, incidental, or consequential damages as a result of the use or the inability to use Hanex Solid Surfaces. This warranty gives you specific legal rights, and you may also have other rights, which vary from state to state, or in Canada, from province to province. Some states/provinces do not allow the exclusion or limitation of implied warranties or of incidental or consequential damages, so the above limitation or exclusion may not apply to you.

Hanwha makes no other guarantee, representation, or warranty (express or implied) with respect to its products, except as expressly stated herein. No one other than Hanwha is authorized or permitted to make or provide any promise, representation or warranty with respect to Hanex Solid Surfaces.

To register, as an alternative to online registration noted above, or make a claim under this warranty, please contact your original dealer and/or fabricator/installer. For other assistance, contact: Hanwha L&C USA LLC., 2389 Paces Ferry Road, Suite 200, Atlanta, GA 30339, Toll Free: 888.426.9421 or 770.431.6110

hanhasurfaces.com



COMMERCIAL 10-YEAR LIMITED WARRANTY for North America

Hanwha L&C Corporation (hereunder "Hanwha") warrants to the original purchaser or owner in the U.S. and Canada that its product Hanex Solid Surfaces, when fabricated and installed by Certified Hanex Solid Surfaces fabricator/installer for commercial use, shall be free from defect in material, under normal use and service, for ten (10) years from the date of sale to the original purchaser. Hanwha, at its discretion, will provide Hanex Solid Surfaces material only, free of charge, for product failures due to manufacture defect during the 10 years following initial installation. The commercial warranty is not transferable.

Exclusions for Hanex Solid Surfaces 10-Year Limited Warranty:

1. Failure to comply with Hanwha's recommended storage, handling, fabrication and installation, and Care & Maintenance guidelines.
2. Damage caused by accidents, abuse, misuse, fabrication/installation error, exposure to extreme heat, or act of nature.
3. Installed Hanex Solid Surfaces product that is removed from their original place of installation or alteration/repair performed on product by one other than Certified Hanex Solid Surfaces fabricator/installer.
4. Appearance of joints or seams due to improper fabrication/installation or improper grout or caulk due to improper maintenance.
5. Minor conditions such as scratches, stains, water spots, and burns, which may be corrected by Hanex Care & Maintenance instructions/guidelines.

No other warranties, express or implied, are made, including merchantability or fitness for a particular purpose. Except as provided herein, Hanwha is not liable for any loss of direct, incidental, or consequential damages as a result of the inability to use Hanex Solid Surfaces. This warranty gives you specific legal rights, and you may also have other rights, which vary from state to state. Some states do not allow the exclusion or limitation of implied warranties or of incidental or consequential damages, so the above limitation or exclusion may not apply to you.

To register or make a claim under this warranty, contact your original dealer or fabricator/installer or for further assistance, contact: Hanwha L&C USA LLC., 2389 Paces Ferry Road, Suite 200, Atlanta, GA 30339, Toll Free: 888.426.9421 or 770.431.6110

Hanex® Solid Surfaces



Classics

This collection brings you endless design possibilities with a wide variety of color combinations, textures and hues-inspired by the wonder of nature.

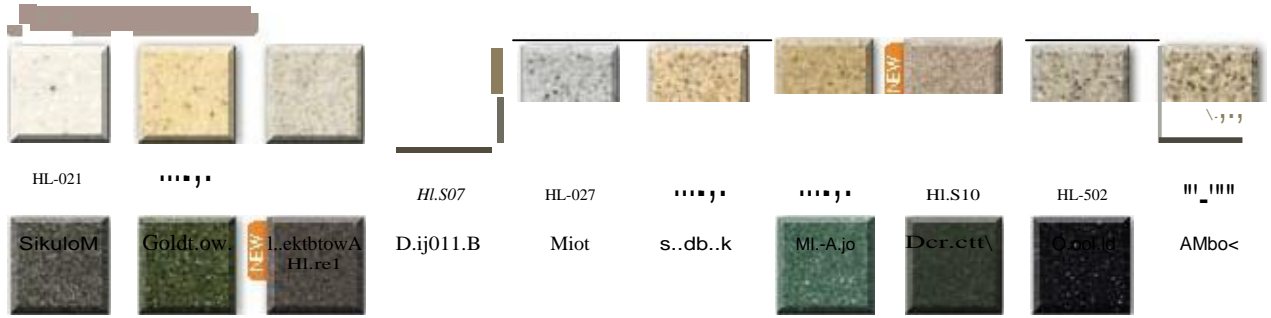

HL-021 HL-022 HL-023 HL-024 HL-025 HL-026 HL-027 HL-028 HL-029 HL-030

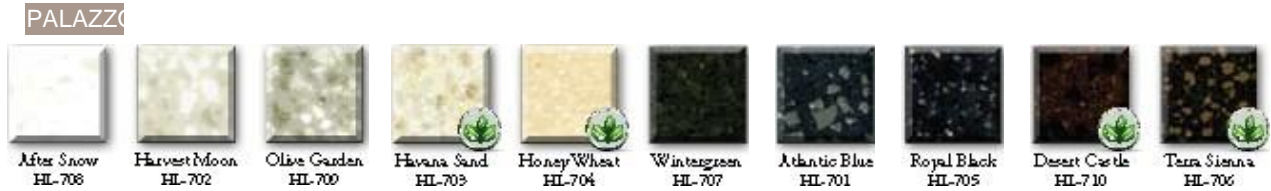
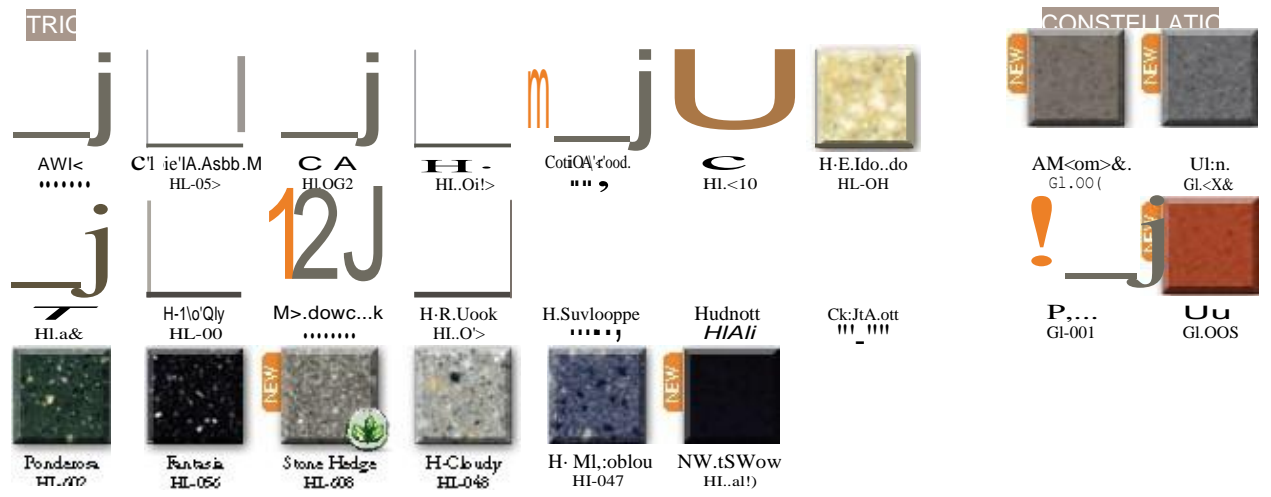

Colors are representative and may vary slightly from the actual product.

 Products made with pre-consumer recycled chip content

SECTION
Delivered.



Bellissimo

Inspired by patterns and colors found in nature the Bellissimo collection creates a luxurious, sophisticated design appeal - all while being distinctively green.



Celadon
BL-002



Maple Wood
BL-006



Trebarro
BL-005



Latte
BL-009



Pietra Panna
BL-003



Mayfair
BL-007



Terracotta
BL-010



Wine Black
BL-012

Brionne

Crisp, clean and pure describes the essence of Brionne. This unique collection features a soft, luminous sheen, and a rich array of patterns and colors. No matter what combination of shapes and hues you choose, the result is sure to be visually pleasing.



Sun Stone
B-012



Bosque
B-013



Ruby Pink Stone
B-019



Flamingo
B-002



Leche
B-028



Siesta
B-020



Havana
B-009



Dancing Quartz
B-016



Orange Moon
B-022



Tumoro
B-025



Aura
B-024



Terra
B-030

Colors are representative and may vary slightly from the actual product.



Contact Information

Global Headquarters

Hanwha L&C Corporation
Hanwha Bldg,
1 Changgyo-dong, Chung-gu
Seoul, Korea 100-797

North American Office

Hanwha L&C | Surfaces
2839 Paces Ferry Rd.
Suite 200
Atlanta, GA 30339

Hanwha L&C | Surfaces

Toll Free: 888.426.9421
Direct: 770.431.6110
Website: hanwhasurfaces.com